

Coolerado M30

SUBMITTAL DATA SHEET



JOB NAME:			LOCATION:	
CONTRACTOR:			PROJECT MANAGER:	
SUPERINTENDENT:			SUBCONTRACTOR:	
PURCHASER:			ORDER NO:	
ENGINEER:			PROJECT MANAGER:	
SUBMITTED TO:	FOR:	REF:	APPROVAL:	CONSTRUCTION:
SUBMITTED BY:			DATE:	
UNIT DESIGNATION:			SCHEDULE NO:	MODEL NO:

Cooling Performance

Outdoor Design Temperature . . . _____ °F DB, _____ °F WB
 Elevation Above Sea Level _____ FT
 Intake Air External Static Pressure _____ IWG
 Intake Air Flow _____ CFM
 Conditioned Air Ext. Static Pressure _____ IWG
 Total Conditioned Air @ Full Speed. _____ CFM
 Conditioned Air Temperature (+/- 2). _____ °F DB
 Conditioned Air Added Humidity _____ °F DP
 Working Air External Static Pressure _____ IWG
 Working Air Flow _____ CFM

Electrical Data

200-240V, 50-60Hz, 790W max., 4.0 Amp, EC Motor
 (200 - 270 V with control transformer change by special request)
 IFM Max Continuous BHP. 0.75
 FLA 5
 Power Supply (max. overcurrent protection). 20
 Min. unit disconnect FLA 10
 Ampacity 15 - 20
 Min. wire size 14 AWG w/ ground
 External Fusing 10 - 20 amp
 Phase 1
 HZ (require to spec). 50/60
 Power input requirement (watts) 550
 EC, backward curved impeller, 3D, 500mm diameter.

Total Unit Weight/Shipping Dimensions

Dry Install Weight. 240 LBS
 Operating Weight (wet) 270 LBS
 Shipping Dimensions 30"W x 52"L x 52"H, 315 lbs

Water

Minimum Flow with 1/2" NPT Connection 1 GPM
 Supply Line Pressure 26 - 65 PSI

Configuration _____ Indoor _____ Outdoor
 Working Air Connections . . . _____ L Side _____ R Side _____ Top

Factory Options

Thermostat with auto-variable motor speed control
 Insulated Product Air Plenum
 Working Air Louver(s), Replaces Side Access Panel(s) 1 2

Standard Features

- 1 year limited warranty
- EER 40+ (Energy Efficiency Ratio)
- Cooling capacity increases as ambient temperature increases
- Low maintenance, simple winterization
- Low water use
- New, patented thermodynamic cycle
- ABS pan, frame, and internal components
- Powder coated, electro-galvanized steel housing
- All electrical/water connections can be accessed from front panel
- Easy to connect power/control wiring
- Integrated control module for reliable, economical operation
- Patented, high technology, poly heat and mass exchanger (HMX)
- Biocide integrated into HMX fibers
- Removable panels - greater durability, ease of access
- No chemical refrigerants or ozone depleting chemicals
- No humidity added or removed
- Fresh, outside air for better indoor air quality (IAQ)
- Filtered air with reduced dust, pollens and allergens
- Air filters - 2 standard size 20" x 25" x 2" air filters
- Tapered intake air plenum for fan efficiency/even air distribution
- Starting collar molded into fan intake for easy duct connection
- Conditioned air plenum provided – accommodates most any size, shape, duct
- Optional factory working air louver can be mounted in side access panel
- Compact, easy to install, ideal height 46.25" cabinet
- High efficiency, electronically commutated motor (ECM)
- Optional auto-variable speed thermostat available
- Top 100 products of 2004 as selected by R&D 100 committee
- GreenSpec® Listed as 2006 Top 10 Green Building Products
- Supplied with water filter (30 nominal micron, 9.875" cartridge)

Coolerado M30 Fan and Performance Table

External Static Pressure (Inches H2O)	Full Speed Product Air Flow (CFM)	Full Speed Product Air Flow (LPS)	Full Speed Product Air Flow (M ³ /S)	Product Air Wet Bulb Approach	Product Approx. Wet Bulb Plus T	Working Air Flow (CFM)	Working Air Flow (LPS)	Working Air Flow (M ³ /S)
0.0	900	425	.42	93%	3	710	335	.34
0.1	850	401	.40	94%	2	680	320	.32
0.2	800	376	.38	95%	2	640	302	.30
0.3	750	354	.35	96%	1	610	288	.29
0.4	710	335	.34	98%	1	580	274	.27
0.5	660	311	.31	100%	0	540	255	.25
0.6	610	288	.29	103%	-1	510	241	.24
0.7	560	264	.26	107%	-2	470	222	.22
0.8	510	241	.24	110%	-3	430	203	.20
0.9	460	217	.22	113%	-4	390	184	.18
1.0	420	198	.20	117%	-5	360	170	.17

Example: Design 98 DB / 62 WB, 0.1" ext. static,
 $98 - 62 = 36$, $36 * 0.95 = 34.2$, $98 - 34.2 = 63.8$ °F Product Air Temperature \approx
 Design WB + 2 = 64 °F

Control Systems



Optional Auto-Variable Speed Thermostat
 Surface Mounted
 3.5"W x 5"H x 1.25"D
 Requires 4 Low Voltage Conductors

Clearance Tolerances

Minimum Clearances:
Sides: 0"
Air Intake (fan) Side: 24"
Conditioned Air Plenum Side: 12"
Top: 0"

Working Air
Can come out top
or either side.

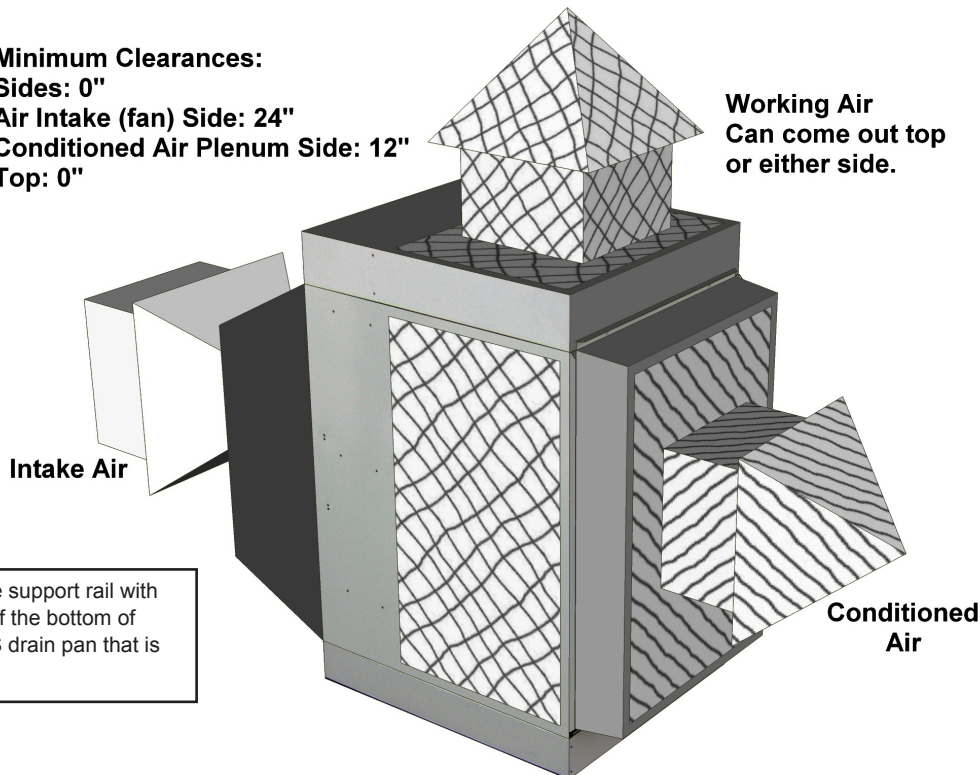

Secure M30 units to angle support rail with screws located within 1" of the bottom of the base. There is an ABS drain pan that is above the bottom 1 inch.

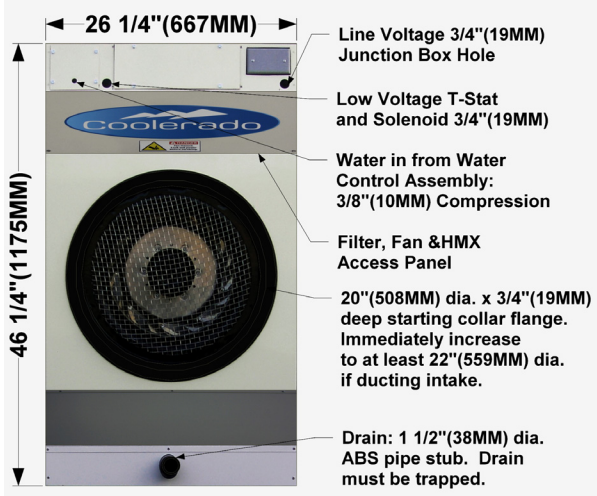

FAN SIDE VIEW

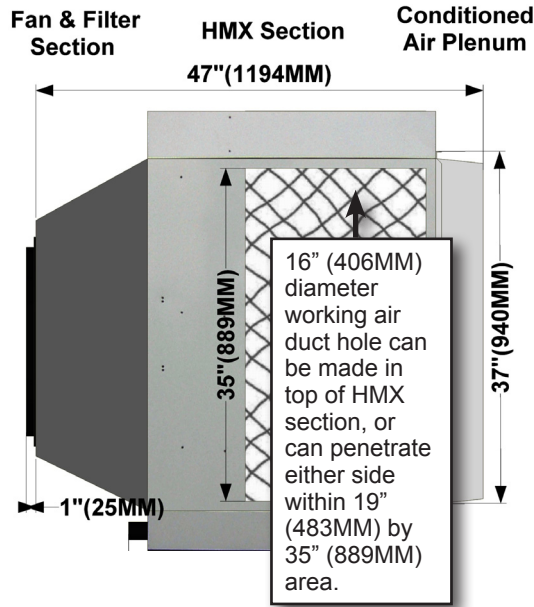

RIGHT SIDE VIEW

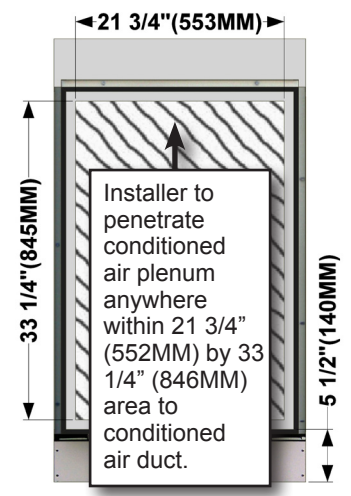

CONDITIONED AIR PLENUM

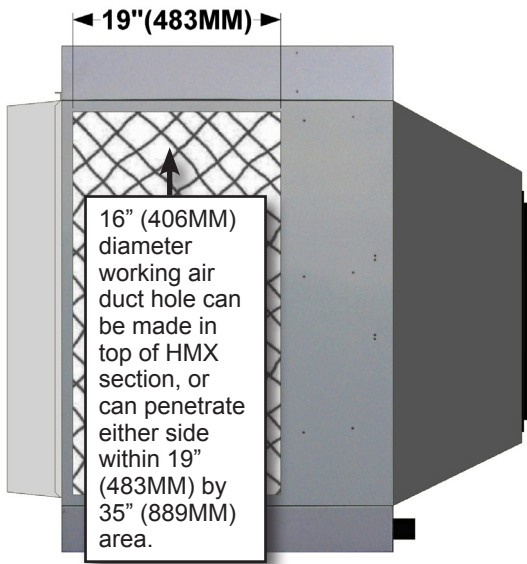

LEFT SIDE VIEW

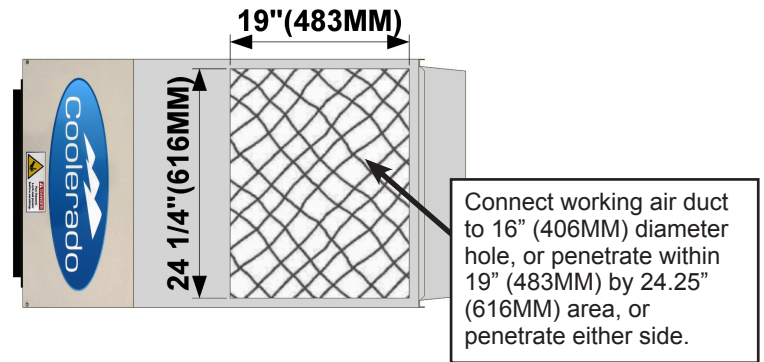

TOP VIEW

Note: Working air is saturated and water will collect in duct connected to working air section. Slope duct drain back into air conditioner, or to appropriate outside location. Avoid low spots in working air ducts.



MODULAR SAMPLE VIEW